

External Dimensions Units: mm

● Small-capacity Series

(1) Rated Torque 2.0 to 7.0 N·m (Outer Diameter 135 mm Inner Diameter 20 mm)

· Applicable Flange: 1

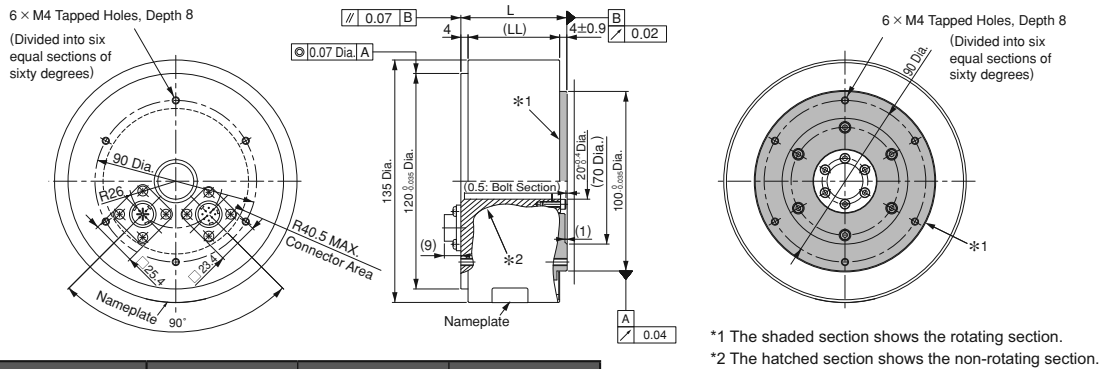

Model SGMCS-	L	(LL)	Approx. Mass kg
02B□C11	59	51	4.8
05B□C11	88	80	5.8
07B□C11	128	120	8.2

· Applicable Flange: 4

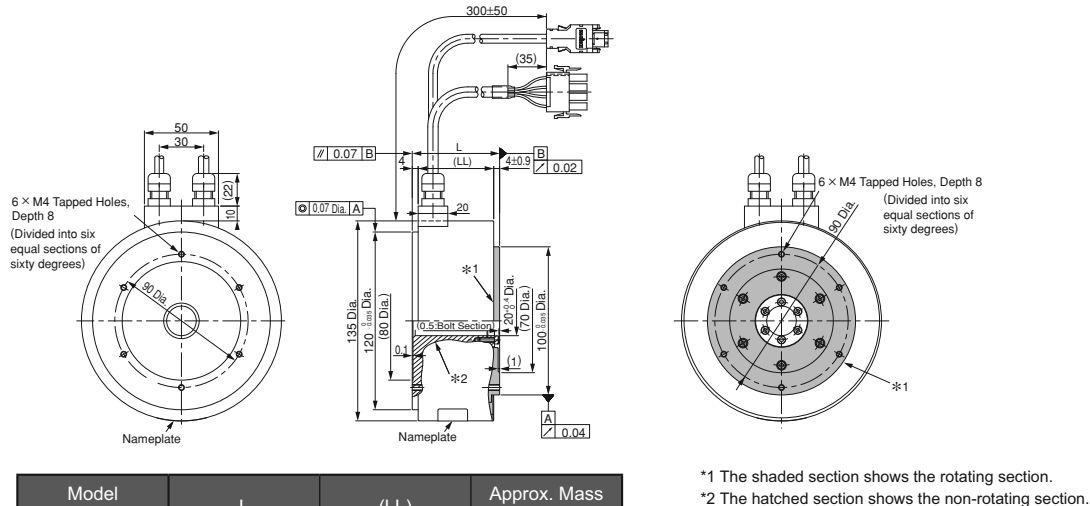

Model SGMCS-	L	(LL)	Approx. Mass kg
02B□C41	59	51	4.8
05B□C41	88	80	5.8
07B□C41	128	120	8.2

● Servomotor Connector for Small-capacity Series Servomotors (Applicable Flange: 1)

Servomotor-end Connector Specifications

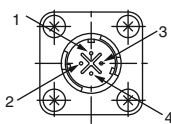

Model: JN1AS04MK2
Manufacturer: Japan Aviation Electronics Industry, Ltd.
Applicable plug: JN1DS04FK1
(Provided by the customer.)

1	Phase U	Red
2	Phase V	White
3	Phase W	Blue
4	FG (Frame ground)	Green (yellow)

Encoder-end Connector Specifications

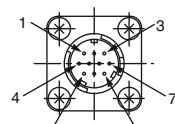

Model: JN1AS10ML1
Manufacturer: Japan Aviation Electronics Industry, Ltd.
Applicable plug: JN1DS10SL1
(Provided by the customer.)

1	PS	Light blue	6	-	-
2	/PS	Light blue/ white	7	FG (Frame ground)	Shield
3	-	-	8	-	-
4	PG5V	Red	9	PG0V	Black
5	-	-	10	-	-

External Dimensions Units: mm

(2) Rated Torque 4.0 to 14.0 N·m (Outer Diameter 175 mm Inner Diameter 35 mm)

· Applicable Flange: 1

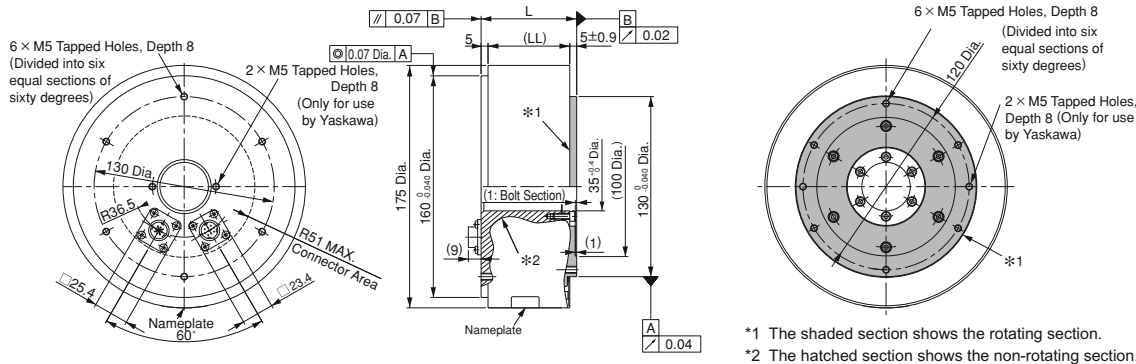

Model SGMCS-	L	(LL)	Approx. Mass kg
04C□C11	69	59	7.2
10C□C11	90	80	10.2
14C□C11	130	120	14.2

· Applicable Flange: 4

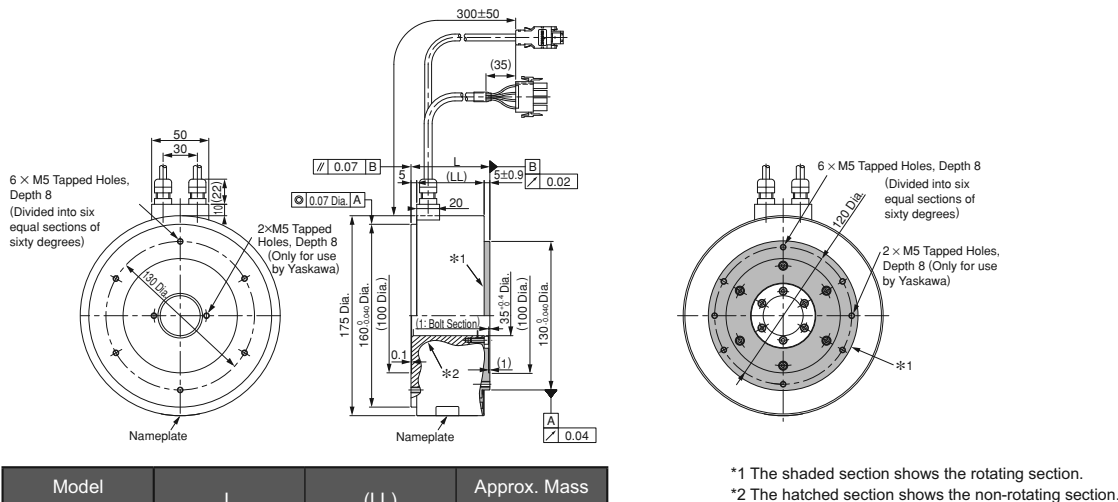

Model SGMCS-	L	(LL)	Approx. Mass kg
04C□C41	69	59	7.2
10C□C41	90	80	10.2
14C□C41	130	120	14.2

● Servomotor Connector (Applicable Flange: 4)

Servomotor-end Connector Specifications

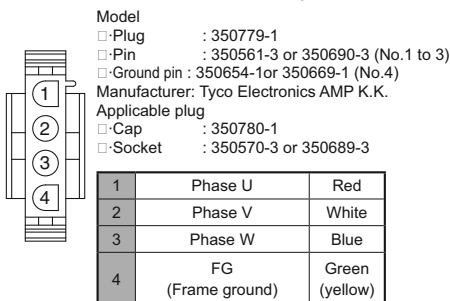

Encoder-end Connector Specifications

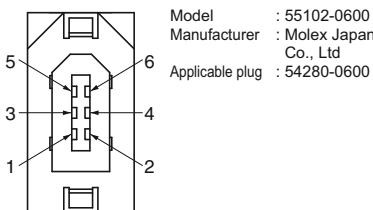

1	PG5V	Red
2	PG0V	Black
3	-	-
4	-	-
5	PS	Light blue
6	/PS	Light blue/white
Connector Case	FG (Frame ground)	Shield

External Dimensions Units: mm

(3) Rated Torque 8.0 to 25.0 N·m (Outer Diameter 230 mm Inner Diameter 60 mm)

· Applicable Flange: 1

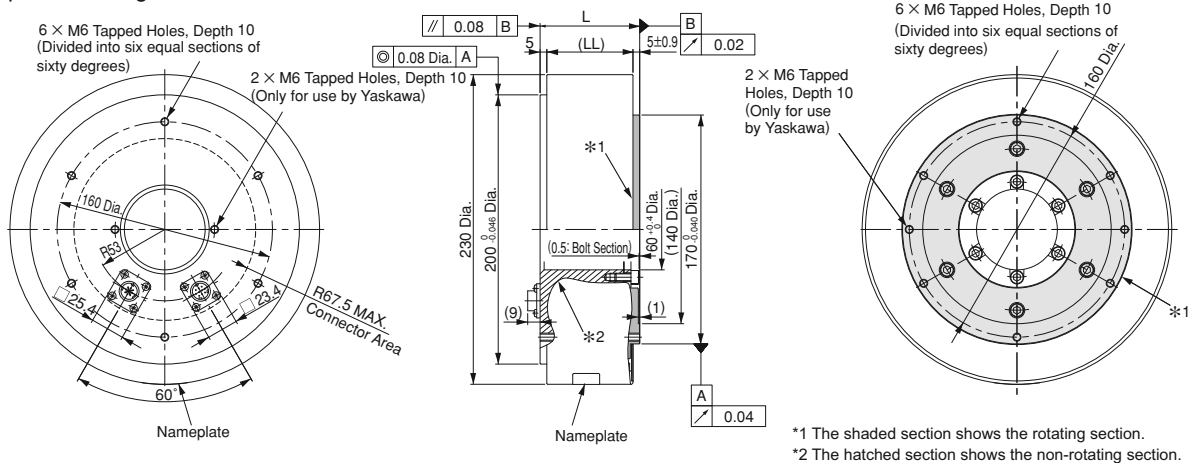

Model SGMCS-	L	(LL)	Approx. Mass kg
08D□C11	74	64	14.0
17D□C11	110	100	22.0
25D□C11	160	150	29.7

· Applicable Flange: 4

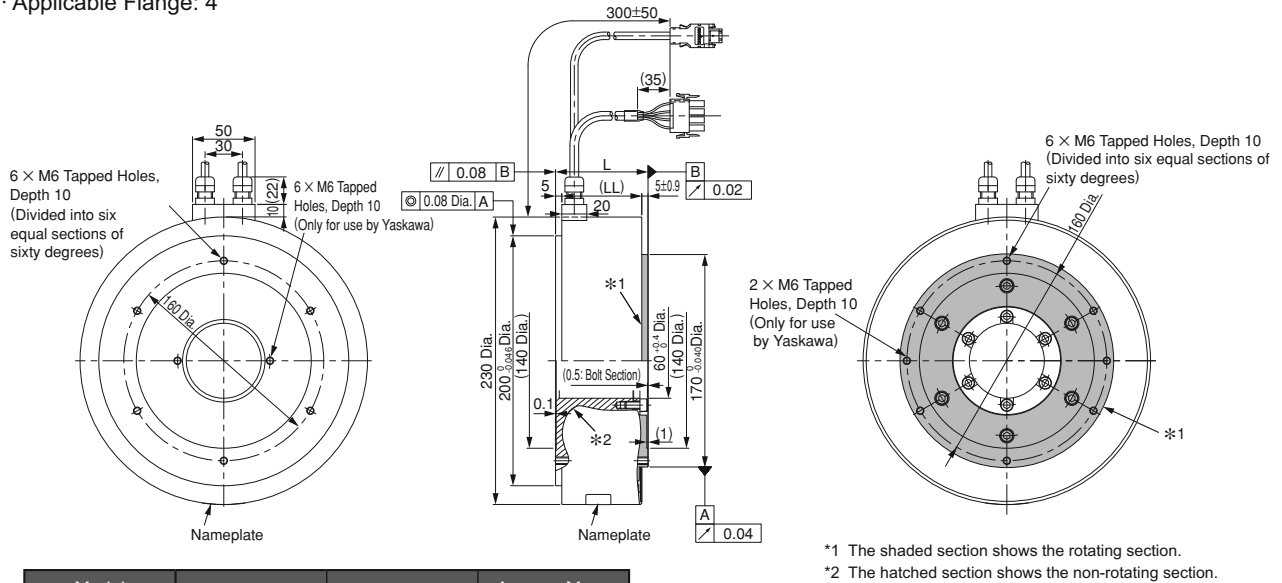

Model SGMCS-	L	(LL)	Approx. Mass kg
08D□C41	74	64	14.0
17D□C41	110	100	22.0
25D□C41	160	150	29.7

External Dimensions Units: mm

(4) Rated Torque 16.0 to 35.0 N·m (Outer Diameter 290 mm Inner Diameter 75 mm)

· Applicable Flange: 1

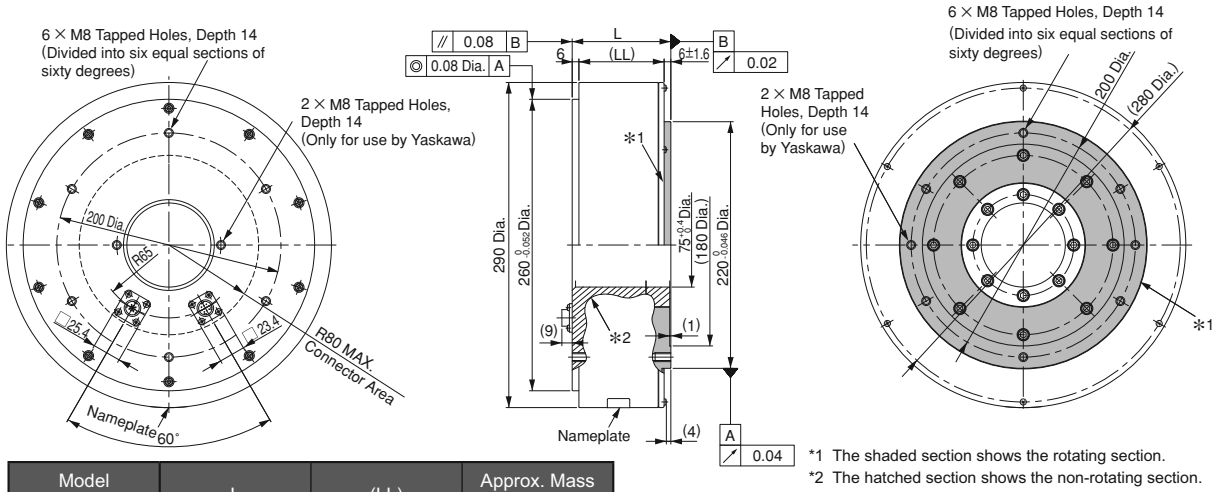

Model SGMCS-	L	(LL)	Approx. Mass kg
16E□B11	88	76	26.0
35E□B11	112	100	34.0

· Applicable Flange: 4

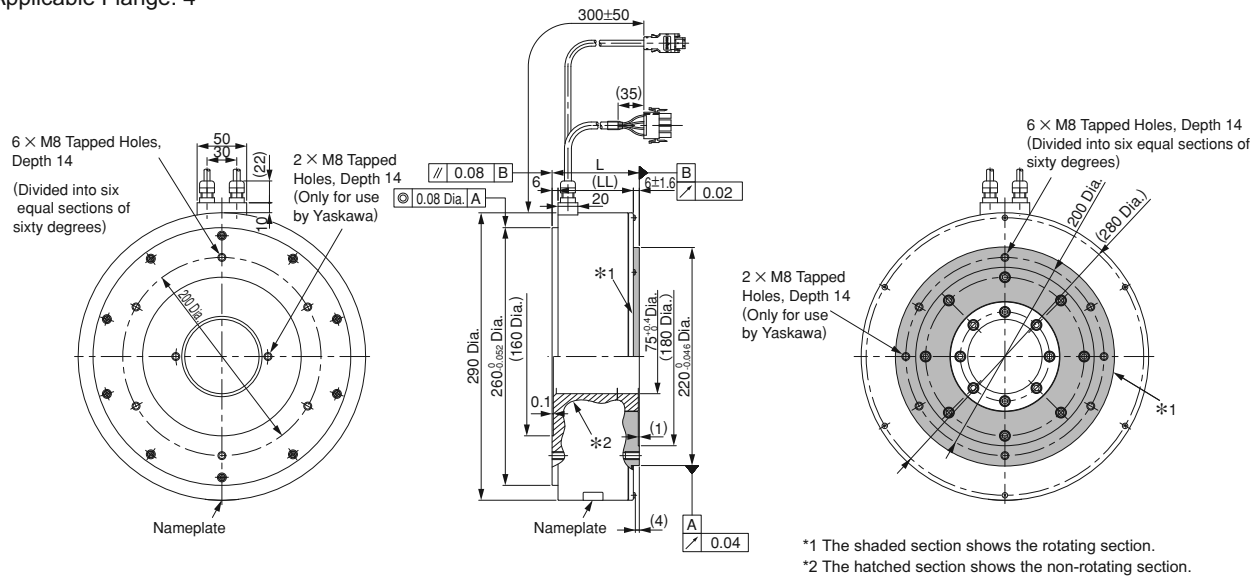

Model SGMCS-	L	(LL)	Approx. Mass kg
16E□B41	88	76	26.0
35E□B41	112	100	34.0

External Dimensions Units: mm

● Medium-capacity Series

(1) Rated Torque 45 to 110 N·m (Outer Diameter 280 mm, Inner Diameter 75 mm)

· Applicable Flange: 1

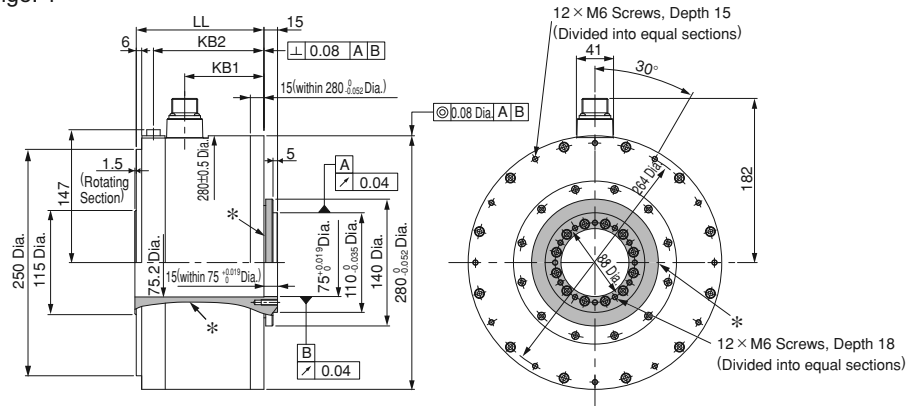

*: The shaded section shows the rotating section.

Model SGMCS-	LL	KB1	KB2	Approx. Mass kg
45M□A11	141	87.5	122	38
80M□A11	191	137.5	172	45
1AM□A11	241	187.5	222	51

· Applicable Flange: 3

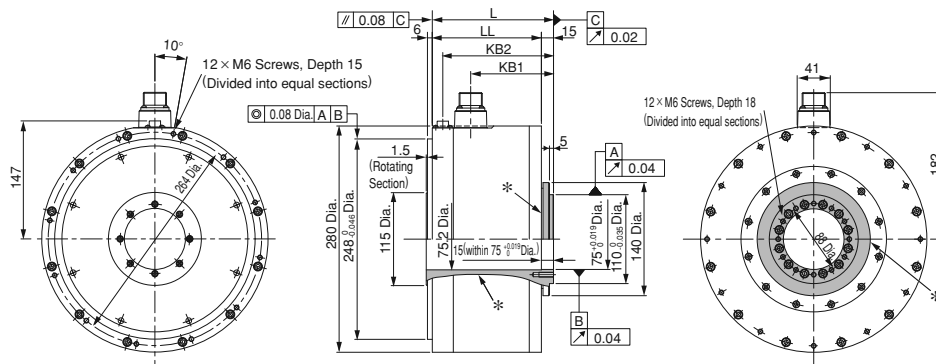

*: The shaded section shows the rotating section.

Model SGMCS-	L	LL	KB1	KB2	Approx. Mass kg
45M□A31	150	135	102.5	137	38
80M□A31	200	185	152.5	187	45
1AM□A31	250	235	202.5	237	51

● Servomotor Connector for Medium-capacity Series Servomotors (Applicable Flange: 1, 3)

Servomotor-end Connector Specifications
(Same for All Medium-capacity Models)

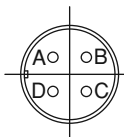

Model : CE05-2A18-10PD
 Manufacturer : DDK Ltd.
 Applicable plug and cable clamp
 Plug : CE05-6A18-10SD-B-BSS
 Cable clamp : CE3057-10A-□(D265)

A	Phase U
B	Phase V
C	Phase W
D	FG (Frame ground)

Encoder-end Connector Specifications
(Same for All Medium-capacity Models)

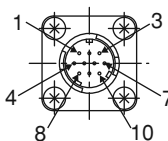

Model : JN1AS10ML1
 Manufacturer : Japan Aviation
 Electronics Industry, Ltd.
 Applicable plug : JN1DS10SL1

1	PS	6	-
2	/PS	7	FG (Frame ground)
3	-	8	-
4	PG5V	9	PG0V
5	-	10	-

External Dimensions Units: mm

(2) Rated Torque 80 to 200 N·m (Outer Diameter 360 mm, Inner Diameter 118 mm)

· Applicable Flange: 1

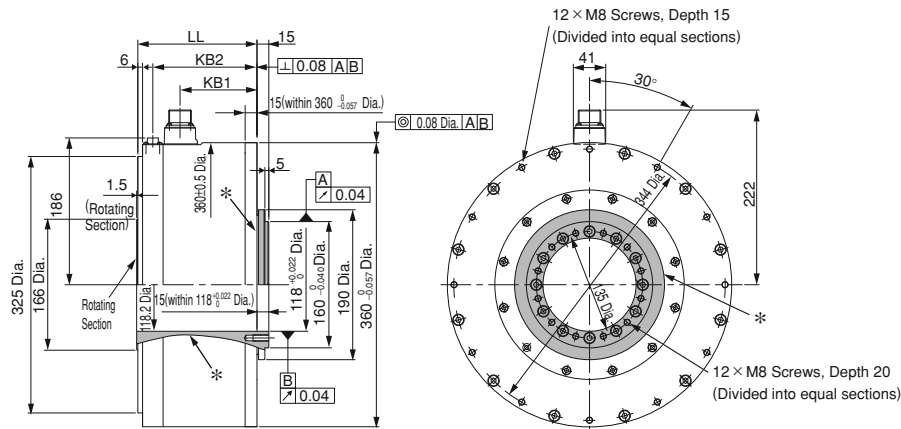

*: The shaded section shows the rotating section.

Model SGMCS-	LL	KB1	KB2	Approx. Mass kg
80N□A11	151	98	132	50
1EN□A11	201	148	182	68
2ZN□A11	251	198	232	86

· Applicable Flange: 3

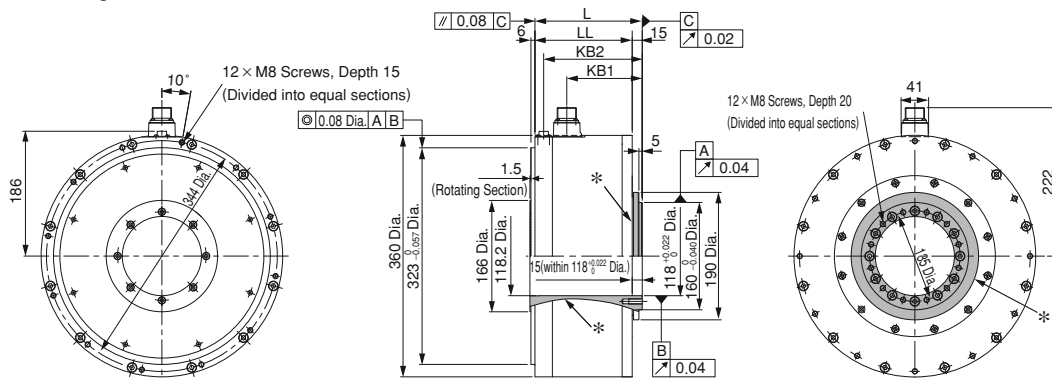

*: The shaded section shows the rotating section.

Model SGMCS-	L	LL	KB1	KB2	Approx. Mass kg
80N□A31	160	145	113	147	50
1EN□A31	210	195	163	197	68
2ZN□A31	260	245	213	247	86

Direct Drive Servomotors